

Description

Triple offset metal to metal seat butterfly valve Titania is specially designed to ensure a perfect tightness in steam, gas, chemical, petrochemical and cryogenic applications.

Product features

- Body types T1 Wafer, T3 Lug, T8 Flange
- Face to face dimension PN10/16/25/40 according to EN558-1
ANSI cl.150/300 according to EN558-1
Table 16 for T1 Wafer and T3 Lug
Table 13 for T8 Flange
- Top flange according to EN ISO 5211
- Rating PN10/16/25/40, ANSI cl.150/300
- Max. working pressure 50 bar
- Temperature range $-196^{\circ}\text{C} \dots +700^{\circ}\text{C}$ according to material
- Tightness test according to API 598
- FIRE SAFE design according to BS 6755 part 2-87, with amendment 2
- ATEX option Execution according to ATEX 94/9/EC, Zone 1 and 21 – Gr II, Cat. 2 G/D



The butterfly valves TITANIA meet the safety requirements of the pressure Equipments Directive 97/23/EC (PED) appendix 1 for fluids of the groups 1 and 2.

Triple offset function:

Offset 1E:

The center of rotation is offset from the tightness surface to allow a total contact around the entire seal.

Offset 2E:

The center of rotation of the disc is offset from the pipe centerline to allow a cleaning opening valve.

Offset 3E:

The third offset issue from the seal cone tilting cancel jamming and friction and allow complete tightness without seal deformation (solid seal).

Tightness:

Bi-directional tightness
Closing without jamming and friction
No deformation on the seal

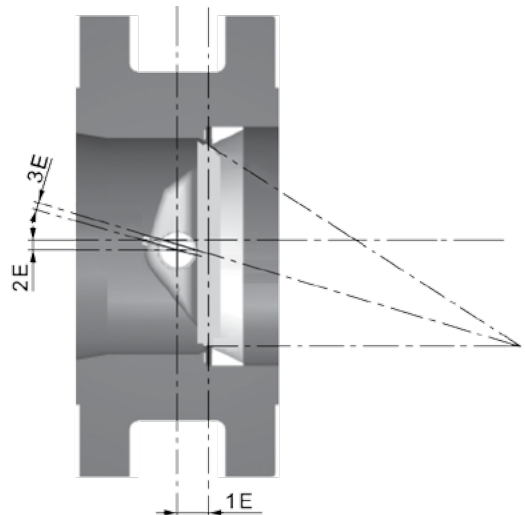
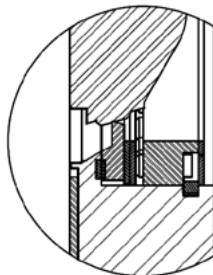

Product features

Flow values k_v [m³/h], Torques [Nm]:

DN	k_v [m ³ /h]	Md [Nm]																
		Δ p 4 bar		Δ p 6 bar		Δ p 10 bar		Δ p 16 bar		Δ p 20 bar		Δ p 25 bar		Δ p 40 bar		Δ p 50 bar		
		o*	c*	o	c	o	c	o	c	o	c	o	c	o	c	o	c	
80	213												59	212	92	251	114	276
100	323												117	275	179	323	221	355
125	323												117	275	179	323	221	355
150	888					153	296	226	320	273	336	333	355	513	415	633	454	
200	1701					356	469	524	504	635	527	774	557	1192	645	1471	703	
250	2780					583	640	854	686	1034	717	1260	756	1937	870	2389	946	
300	4038					888	1042	1337	1123	1636	1177	2008	1245	3132	1449	3880	1584	
350	4984					1228	1189	1855	1280	2272	1341	2794	1416	4359	1642	5403	1793	
400	7128					2005	2059	3072	2223	3784	2333	4674	2471	7343	2883	9121	3158	
450	8150					2614	2525	3964	2719	4866	2849	5993	3012	9372	3499	11625	3824	
500	10460					3874	4038	5870	4352	7201	4562	8865	4824	13856	5609	17182	6133	
600	14674					5953	5537	9128	5976	11244	6268	13889	6634	21824	7731	27115	8461	
700	20095					9793	9666	14858	10414	18234	10912	22454	11536	35114	13407	43556	14653	
800	35791	5099	4962	7522	5430	12608	6094	10649	7090									
1000	52958	10891	8550	15615	9092	26159	10175	41977	11780									
1200	77439	17136	13475	25938	14337	43541	16062											
1400	100987	27284	17504	41096	18608	68717	20814											

* o=open, c=close

Type code

T1 00150 . 3 3 . 3PD . 4A . 4HS . 4X - ATEX

①	Body type	T1	Wafer	DN80-1200			
		T3	Lug	DN80-1200			
		T8	Flange	DN80-1400			
②	Nominal diameter	0080-1400	mm				
③	Working pressure	2	10 bar				
		3	16 bar				
		4	20 bar				
		5	25 bar				
		6	40 bar				
		7	50 bar				
④	Rating	2	PN 10	DN 200-1400			
		3	PN 10 / 16	DN 80-150			
			PN 16	DN 200-1400			
		A	ANSI cl.150	DN 80-1400			
		5	PN 25	DN 200-1400			
		6	PN 25 / 40	DN 80-150			
PN 40	DN 200-600						
⑤	Body	T1 Wafer, T3 Lug	3PD	Cast steel E36-3 / P355GH / 1.0473	T1, T3		
			4B0	Stainless steel X2CrNiMo17-12-1 1.4404	T1, T3 DN 80-450		
			4C0	Stainless steel 1.4408	T1, T3 DN 500-1200		
		T8 Flange	3HD	Cast steel GP280GH 1.0625	T8		
			4C0	Stainless steel A351CF8M 1.4408	T8		
			⑥	Shaft	4A	Stainless steel X20Cr13, 1.4021 (with cast steel body)	
					4L	Stainless steel X5CrNiCuNb16-4, 1.4542 (with stainless steel body)	
			⑦	Disc	3HS	Cast steel 1.0619 A216WCB stellited (with cast steel body)	
4CS	Stainless steel A351CF8M, 1.4408 stellited (with stainless steel body)						
⑧	Seat	4X	Stainless steel GX12CrNiSi25-20, 1.4843				
⑨	ATEX option	ATEX	Execution according to ATEX 94/9/EC, Zone 1 and 21 – Gr II, Cat. 2 G/D				

Mounting the valve at the end of a line on request

Pressure and temperature limits of application are dependent of the working conditions

Dimensions

TITANIA T1 Wafer

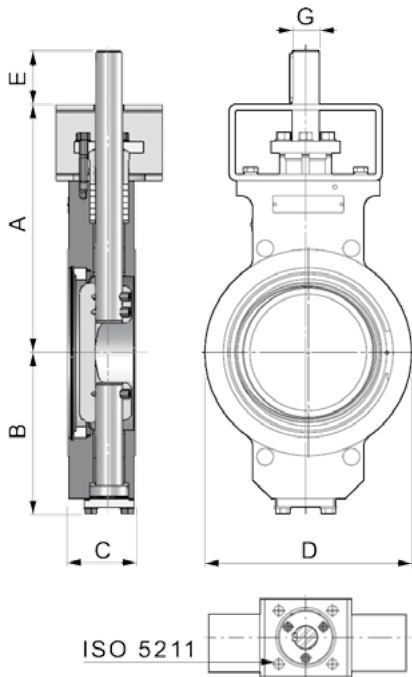

DN	A	B	C	Dmax	E	G	ISO 5211	[kg]					
								PN10	PN16	cl.150	PN25	PN40	cl.300
80	200	119	64	138	35	16	F05-07	11,6	11,6	11	11,6	11,6	11
100	225	143	64	160	45	20	F05-07	16,5	16,5	16,5	16,5	16,5	16,5
125	250	143	70	190	45	20	F05-07	24	24	24	24	24	24
150	295	175	76	216	55	25	F07-10-12-14	31	31	31	31	31	31
200	325	210	89	285	70	35	F07-10-12-14	47,7	47,7	47,7	49,4	51,1	47,7
250	360	247	114	345	75	40	F10-12-14-16	73	73	73	75,5	79,2	73
300	400	287	114	410	80	45	F10-12-14-16	90,3	92	92	98	104,5	92
350	445	322	127	465	85	50	F14-16-25	134,5	138,7	126,2	145	153,3	126,2
400	530	355	140	535	90	60	F16-25-30	186	190	180	198	214	180
450	565	393	152	560	100	65	F25-30	240	255	240	255	264	240
500	652	427	152	615	115	75	F25-30	296	321	296	326	326	296
600	726	502	178	736	130	85	F25-30-35	472	520	472	513	534	472
700	860	574	229	797	150	100	F30-35-40	592	592	592	592	592	592
800	865	646	241	905	115*	75*	F30	858	858				
900	990	710	241	1005	115*	75*	F30-35	1080	1080				
1000	1078	772	300	1117	150*	100*	F30-35	1342	1342				
1200	1243	920	254	1330	165*	110*	F30-40	1675	1675				

* PN10/16

TITANIA T3 Lug

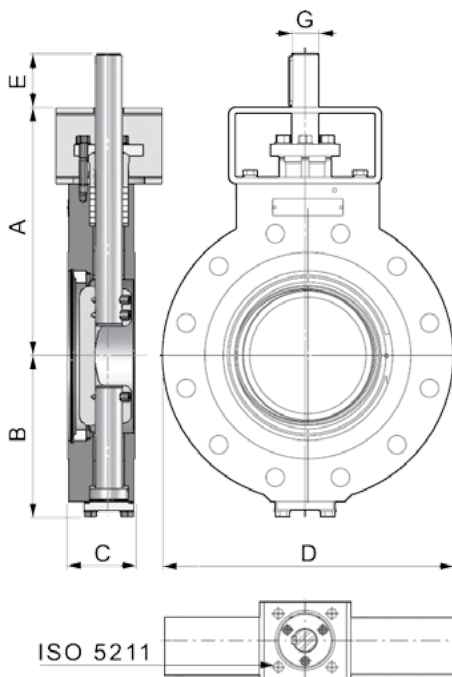

DN	A	B	C	Dmax	E	G	ISO 5211	[kg]					
								PN10	PN16	cl.150	PN25	PN40	cl.300
80	200	119	64	210	35	16	F05-07	15	15	14	15	15	15
100	225	143	64	254	45	20	F05-07	20	20	21	21	21	23
125	250	143	70	279	45	20	F05-07	29	29	29	31	31	32
150	295	175	76	318	55	25	F07-10-12-14	40	40	39	43	43	46
200	325	210	89	381	70	35	F07-10-12-14	63	63	63	68	72	73
250	360	247	114	450	75	40	F10-12-14-16	98	101	101	108	119	117
300	400	287	114	521	80	45	F10-12-14-16	121	126	137	137	154	156
350	445	322	127	582	85	50	F14-16-25	176	185	194	208	226	226
400	530	355	140	660	90	60	F16-25-30	245	256	273	287	316	316
450	565	393	152	711	100	65	F25-30	312	337	337	367	383	410
500	652	427	152	775	115	75	F25-30	379	429	409	446	475	497
600	726	502	178	914	130	85	F25-30-35	594	692	642	692	764	802
700	860	574	229	1035	150	100	F30-35-40	800	800	800	800	800	800
800	865	646	241	1150*	115*	75*	F30	1100	1100				
900	990	710	241	1185*	115*	75*	F30-35	1450	1450				
1000	1078	772	300	1117	150*	100*	F30-35	1800	1800				
1200	1243	920	254	1485	165*	110*	F30-40	2178	2178				

* PN10/16

Dimensions

TITANIA T8 Flange

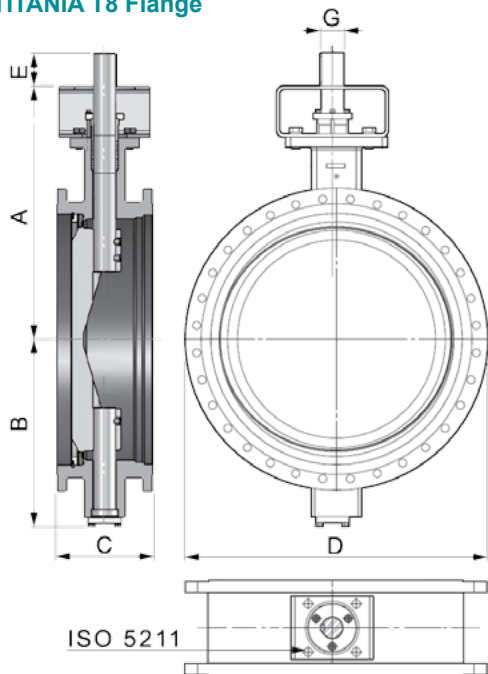

DN	A	B	C	Dmax	E	G	ISO 5211	[kg]	
								PN10/16/25/cl.150	PN40/cl.300
80	200	119	114	210	35	16	F05-07	-	16
100	225	143	127	254	45	20	F05-07	-	25
125	250	143	140	279	45	20	F05-07	-	39
150	295	175	140	318	55	25	F07-10-12-14	-	58
200	325	210	152	381	70	35	F07-10-12-14	68	86
250	360	247	165	450	75	40	F10-12-14-16	97	127
300	400	287	178	521	80	45	F10-12-14-16	131	176
350	445	322	190	584	85	50	F14-16-25	178	235
400	530	355	216	660	90	60	F16-25-30	258	337
450	565	393	222	711	100	65	F25-30	300	400
500	652	427	229	775	115	75	F25-30	420	522
600	726	502	267	914	130	85	F25-30-35	639	820
700	860	574	292	1035	150	100	F30-35-40	784	1029
800	865	646	318	1149	115*	75*	F30	1024	1344
900	990	710	330	1270	115*	75*	F30-35	1437	1844
1000	1078	772	410	1320	150*	100*	F30-35	1850	-
1200	1243	919	470	1485	165*	110*	F30-40	2226	-
1400	1409	1066	530	1685	185*	126*	F40	3091	-

* PN10/16

Gearbox:

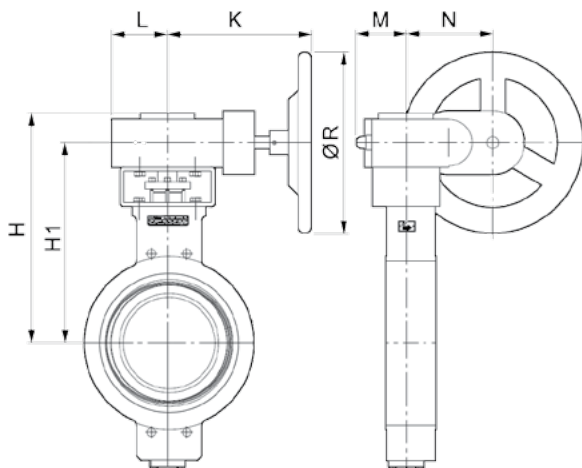

DN	bar		ØR	H	H1	K	L	M	N	T1[kg]	T3[kg]	T8[kg]
80	50	GB210	200	260	227	187	51	51	45	14,8	18,8	20
100	50	GB210	200	285	252	187	51	51	45	19,7	26,2	29
125	50	GB210	200	310	277	187	51	51	45	27,5	35,5	43
150	25	GB210	200	355	322	187	51	51	45	34,8	46,8	62
	50	GB550	250	384	336	238	69	83	71	37,8	49,8	67
200	10	GB550	200	414	366	238	69	83	71	56,5	71,5	77
	25	GB550	300	414	366	238	69	83	71	56,5	75,5	77
200	50	GB880	500	417	367	226	100	101	86	62,0	87,0	101
	10	GB880	250	452	402	226	100	101	86	87,5	115	112
250	25	GB880	400	452	402	226	100	101	86	89,5	122	112
	50	GB1250	700	461	408	330	110	110	105	95,5	139	149
300	10	GB1250	300	501	448	330	110	110	105	113	147	153
	25	GB1250	600	501	448	330	110	110	105	120	159	153
300	50	GB1950	800	525	455	375	143	143	130	124	188	209
	10	GB1950	400	546	493	330	110	110	105	158	203	200
350	25	GB1250	800	546	493	330	110	110	105	168	230	200
	50	GB1950/SP4	400	556	500	405	143	143	211	213	286	295
400	10	GB1950	500	655	585	375	143	143	130	219	284	290
	25	GB1950	800	655	585	375	143	143	130	231	319	290
400	50	GB6800	800	690	589	400	185	170	182	237	372	393
	10	GB1950/SP4	200	720	620	405	143	143	211	300	372	350
450	25	GB1950/SP4	400	720	620	405	143	143	211	315	427	350
	50	GB6800/SP4	500	724	624	488	185	170	263	311	480	480
500	10	GB1950/SP4	300	807	707	405	143	143	211	356	439	480
	25	GB6800/SP4	400	811	711	488	185	170	263	397	516	490
500	50	GBA250/SP9	300	826	737	599	255	235	431	522	722	747
	10	GB6800/SP4	250	885	785	488	185	170	263	543	714	709
600	25	GB6800/SP4	600	885	785	488	185	170	263	543	762	709
	50	GBA250/SP9	500	900	811	599	255	235	431	698	965	1045

Further documentation

Pneumatic actuators, Electric actuators, Accessories according separate data sheets.

Installation guide, Maintenance guide, Flanges: Please consult these guides for the installation and maintenance of our butterfly valves.

InterApp AG
Grundstrasse 24
CH-6343 Rotkreuz
Phone +41 (0) 41 7982233
Fax +41 (0) 41 7982234
info@ch.interapp.net

InterApp Austria
Kolpingstrasse 19
A-1230 Wien
Phone +43 (0) 1 6162371-0
Fax +43 (0) 1 6162371-99
info@at.interapp.net

InterApp Italy
Via Gramsci 29
I-20016 Pero (MI)
Phone +39 02 339371
Fax +39 02 33937200
info@it.interapp.net

InterApp Singapore
11, Changi North Street 1, #03-11
Singapore 498823
Phone +65 62141048
Fax +65 62140481
info@sg.interapp.net

AVK Mittelmänn Armaturen
InterApp Germany
Schillerstrasse 50
D-42489 Wülfrath
Phone +49 (0) 2058 901 01
Fax +49 (0) 2058 901 110
info@avkmittelmänn.com

AVK Válvulas S.A.
InterApp Válvulas S.A.
Polígono Industrial Francoali, parcela 12
E-46006 Tarragona
Phone +34 977 543 008
Fax +34 977 541 622
avk@avkvalvulas.com

The technical data are noncommittal and do not assure you of any properties. Please refer to our general sales conditions. Modifications without notice.

© 2012 InterApp AG, all rights reserved