

INSTALLATION, OPERATION & MAINTENANCE MANUAL

INDEX

	<u>Page</u>
0.- Description	2
1.- Handling	2
2.- Installation	2
3.- Actuators	5
4.- Maintenance	5
4.1.- Gland packing replacement	5
4.2.- Seal replacement.....	6
4.3.- PTFE seal replacement	7
4.4.- Lubrication	8
5.- Storage	8
6.- Parts list & drawing	9



0.- DESCRIPTION

The VP model knife gate is a through-conduit bi-directional wafer valve designed for high consistency fluids. The double seat design assures a non-clogging shut off on either normal or reverse flow.

1.- HANDLING

When handling an Orbinox valve please pay attention to the following points:



- **Do NOT attach lifting gear to the valve actuators or gate guards.** They are not designed to bear the weight, and could easily be damaged.
- **Do NOT lift the valve by the valve bore.**
This can cause damage to the seating surfaces and seals.

Ideally when using lifting gear to move an Orbinox valve, it should be supported by two or more eyebolts screwed into the tapped fixing holes in the valve body.

SAFETY WARNING:

- Check that the lifting gear is rated to carry the weight of the valve.
- Make sure the eyebolts have the same thread as the boltholes and that they are well secured.

During installation it is recommended to lift the valve via soft straps. These can be to the upper part of the valve body.

2.- INSTALLATION



To avoid personal injury or damage to property from the release of process fluid:

- Those in charge of handling and maintenance of the valve must be qualified and trained in valve operations.
- Use appropriate personal protection equipment (gloves, safety shoes, etc).
- Shut off all operating lines to the valve and place a warning sign.
- Isolate the valve completely from the process.
- Release process pressure.
- Drain the process fluid from the valve.

Before installation, inspect the valve body and components for any damage that may have occurred during shipping or storage. Make sure the internal cavities within the valve body are clean. Inspect the pipeline and mating flanges, making sure the pipe is free of foreign material and that the flanges are clean.

The VP valve is bi-directional. Both standard (Type A) and reinforced construction (Type B) can be installed without taking the direction of fluid into consideration.

However, valves provided with a deflection cone (Type C) are unidirectional. It is vital that they be installed correctly with respect to the direction of the flow. Correct installation is the responsibility of the user.

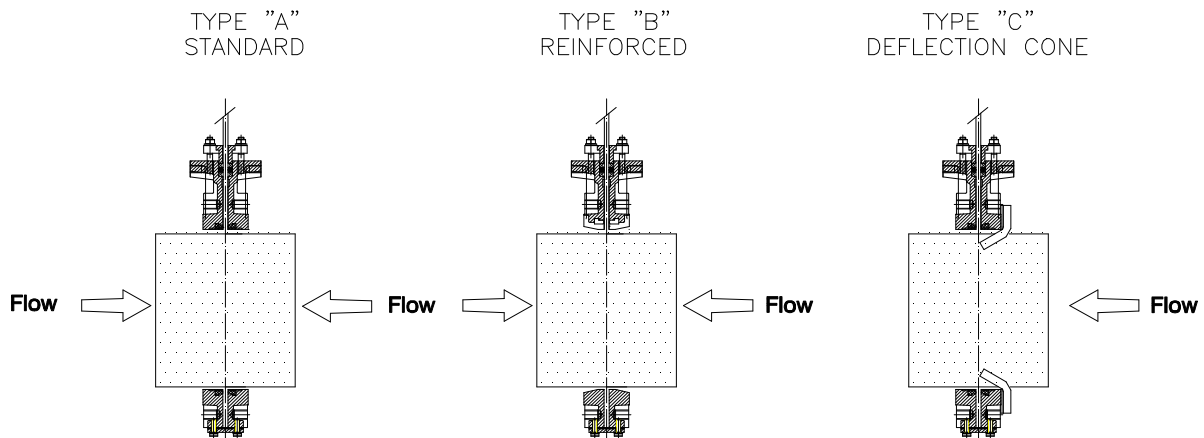

Special care should be taken to maintain the correct distance between the flanges and to ensure that they are parallel to the valve body. Incorrect alignment of the valve can cause deformations, which can lead to difficulties in operation.

Place the valve between flanges. First tighten the side bolts (1) and then the upper and lower bolts (2).

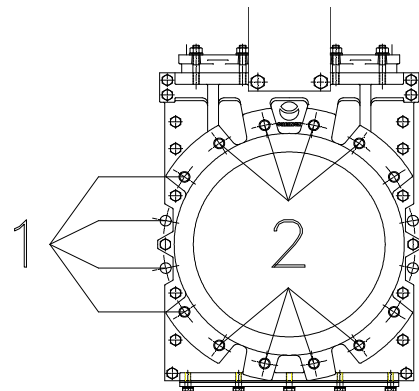

The following table gives the maximum torque values for the valve fixing bolts. Also shown is the maximum depth (T) allowed for the tapped blind boltholes drilled into the valve body.

DN	50	65	80	100	125	150	200	250	300	350	400	450	500	600
T (mm)	8	8	9	9	9	10	12	12	12	15	15	15	20	20
Kg.m	6	6	6	6	7	7	7	11	11	15	15	19	19	23

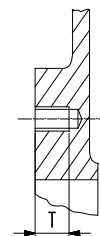

The valve can be mounted in any position with regard to the pipe. However, it is advisable to place it vertically in horizontal pipeline (A) if the installation allows it. (Please consult the technical department at Orbinox).

With larger diameters (> 300 mm), heavy actuators (pneumatic, electric, etc.), or with the valve installed horizontally (B) or at an angle (C) on a horizontal pipeline, the installation will require the construction of suitable supports. (See the following diagram and consult the technical department at Orbinox).

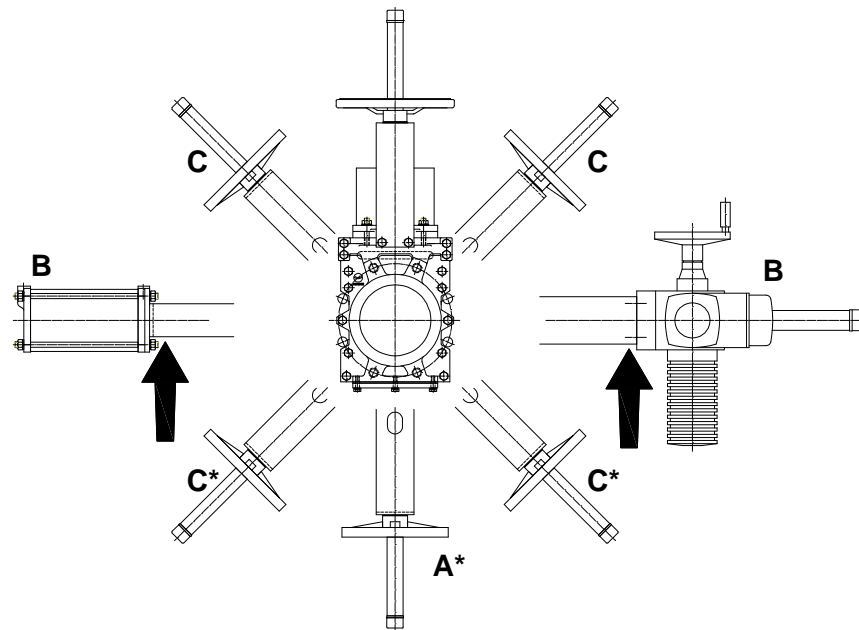

** For these positions please consult Orbinox.*

In vertical pipelines, the construction of suitable supports is always required (for further information please consult the technical department at Orbinox).

Once the valve is installed, test that the flanges have been fastened correctly and that all electrical and/or pneumatic connections have been properly made.

Where electric accessories are mounted on the valve (i.e. solenoid valves, electro-pneumatic positioners, etc.), the valve must be earthed correctly before being put into operation.

First, operate the valve with no flow in the pipeline. Then test operation and valve seal with flow. It should be noted that the packing material might settle in shipping/storage, which can cause minor leakage. This can be remedied by tightening the gland follower (5) during installation. Once performance has been tested, the valve can be put into operation.

3.- ACTUATORS

3.1.- Handwheel

To open the valve turn the handwheel (12) anticlockwise. To close turn the handwheel clockwise.

3.2.- Lever

To operate the valve with this device, first loosen the locking clamp located on the top of the yoke (9). Then either open or close the valve by moving the lever in the desired direction. Finally, fix the position of the lever with the locking clamp.

3.3.- Pneumatic

Valves are usually supplied with a double acting pneumatic actuator although, upon request, we can supply single-acting actuators. In both cases, the inlet air pressure should be, between 3,5 to 10 Kg/cm².

It is essential for a good maintenance of the cylinder that air should be well dried, filtered and lubricated.

It is recommended to actuate the cylinder 3-4 times before the start up, once it is installed in the pipeline.

3.4.- Electric actuator

Depending on the type or make of the electric actuator, specific instructions (i.e. a manufacturer's manual) will be supplied.

4.- MAINTENANCE



To avoid personal injury or damage to property from the release of process fluid:

- Those in charge of handling and maintenance of the valve must be qualified and trained in valve operations.
- Use appropriate personal protection equipment (gloves, safety shoes, etc).
- Shut off all operating lines to the valve and place a warning sign.
- Isolate the valve completely from the process.
- Release process pressure.
- Drain the process fluid from the valve.

The only maintenance required is to change the gland packing (5) or the seal (4) if the valve is a resilient seated type.

The life of these elements will depend on the working conditions of the valve such as: pressure, temperature, abrasion, chemical action, number of operations, etc.

For a better operation of the valve, it is convenient to carry out a periodic cleaning of the inferior part, accessible from the splash guard.

4.1. - Replacement of the gland packing (5):

- 1) Depressurise the circuit and place the valve in close position.
- 2) Remove the gate guards (for automatically actuated valves only).
- 3) Release the spindle or stem (7) from the gate (3).
- 4) Loosen the screws of the yoke (9) and remove it (without losing the actuator).
- 5) Loosen the nuts of the gland follower (6) and remove it.
- 6) Remove the old packing rings (5) and clean the stuffing box.
- 7) Insert the new packing rings (5), making sure that the ring joints alternate (the first on one side of the gate, the next on the other and so on).
- 8) Once the necessary packing rings (5) have been inserted, proceed with a steady initial tightening of the gland follower (6).
- 9) Place the yoke (9) (with the actuator) and screw it.
- 10) Fix the stem (7) to the gate (3).
- 11) Remount the gate guards.
- 12) Carry out some operations with a loaded circuit and then re-tighten the gland follower (6) to prevent leakage.

4.2.- Replacement of the seal (4) (only applicable to resilient seated valves):
The seat type will depend on the material of the valve.

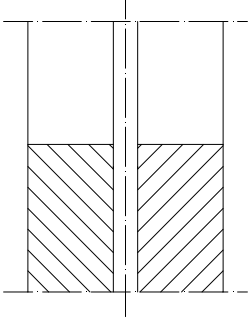
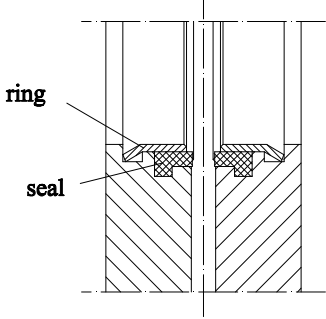
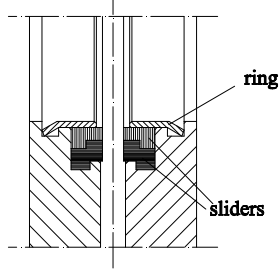
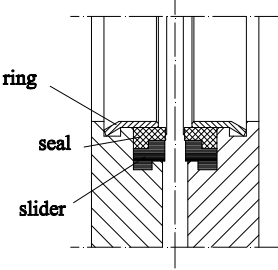
<p>Body VP: GG25 ND50-600</p> <p>Body VP: CF8M ND 50-150</p>	 <p style="text-align: center;">Metal seal</p>	 <p style="text-align: center;">Resilient seal</p>
<p>Body VP: CF8M ND 200-600</p>	 <p style="text-align: center;">Metal seal</p>	 <p style="text-align: center;">Resilient seal</p>

- 1) Remove the valve from the pipeline.
- 2) Remove the gate guards (for automatically actuated valves only).
- 3) Release the spindle or stem (7) from the gate (3).(Rising stem valves.) or release the stem nut from the gate.(Non rising stem.).
- 4) Loosen the screws of the yoke (9) and remove it (without losing the actuator).
- 5) Loosen the nuts of the gland follower (6) and remove it.
- 6) Remove the old packing (5) and the gate (3) and clean the stuffing box.
- 7) Loosen the nuts of the cover (14) and remove it.
- 8) Split the two half bodies (1,2) and clean internally.
- 9) Remove the seal retainer rings (11) which support the seals (4) (and/or the sliders for the stainless steel ND \geq 200 bodies).
- 10) Remove the worn seal (4) (and/or the sliders for the stainless steel ND \geq 200 bodies) and clean the seal housing.
- 11) Re-insert the sliders; ensure that the join is at the top (only stainless steel ND \geq 200 bodies).
- 12) Once the new seal (4) has been cut, according to size, insert it into the seal housing ensuring that the seal join is at the top (only tight shut-off valves) (Photo 1). With stainless steel bodied valves, make sure that the slider join does not coincide with the seal join.

If the valve has PTFE seal (4), follow the point 4.3.

Seal lengths

ND	50	65	80	100	125	150	200	250	300	350	400	450	500	600
Lengths (mm)	205	255	295	365	440	510	680	860	1020	1190	1350	1510	1630	2010

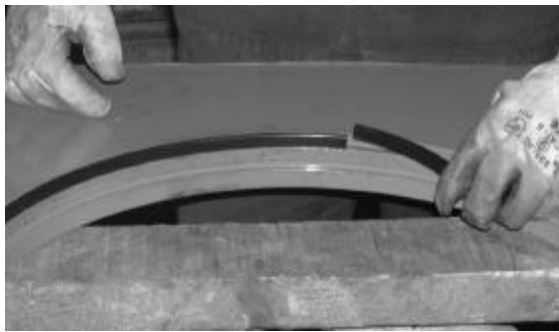

Photo 1



Photo 2

- 13) Insert the seal retainer ring (11) by hammering gently around the edge. (Photos 2 and 3)



Photo 3



Photo 4

- 14) Position the gaskets (Photo 4) and the gate (3) between the two halves of the valve body. Lubricate the gate (3) and the inner parts of the slide-way, and then bolt the two halves together.
 15) Remount the cover (14).
 16) Finish the assembly, following the steps of the point 4.1.

4.3. - Replacement of the PTFE seal (4):

Follow the same procedure as point 4.2 but with following notes:

- To obtain a tighter shut off in stainless steel valves (CF8M body), the machined housing of the seat is sealed with a plastic glue. This is not necessary in cast iron valves (GG25).
 With the seal in this position:



- Make a circle, joining the ends and making a heart-shaped form (see the following diagram).

3. Insert both ends of the seal in the upper side of the machined area of the seat (at the actuator end of the body), and pushing the arched part with a finger, insert the seal into the seat.

If the diameter of the valve is small ($ND \leq 150$), a vice can be used.

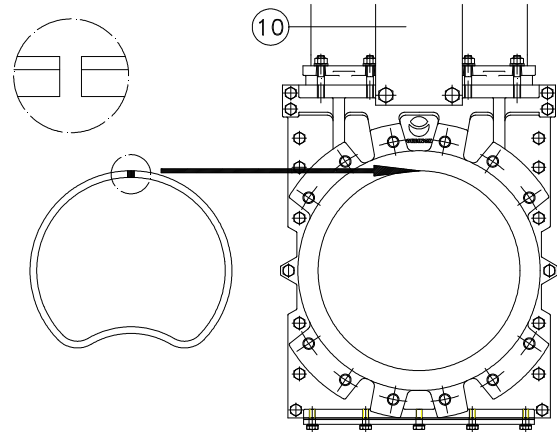

4.4. - Lubrication:

Twice a year, it is recommended to remove the protection cap (13) and fill up the stem protector (10) halfway with a calcium-based grease with the following characteristics: highly water resistant, low ash content, and excellent adherence.

5.- STORAGE

For long periods it is recommended to store the valves in a well-ventilated room. Valves should not be exposed to temperatures higher than 30°C, as some soft seal materials can be damaged when exposed to higher temperatures.

If outdoor storage cannot be avoided, cover the valve and protect it from sources of heat or direct sunlight. Provide good ventilation to avoid moisture.

6.- PARTS LIST & DRAWINGS

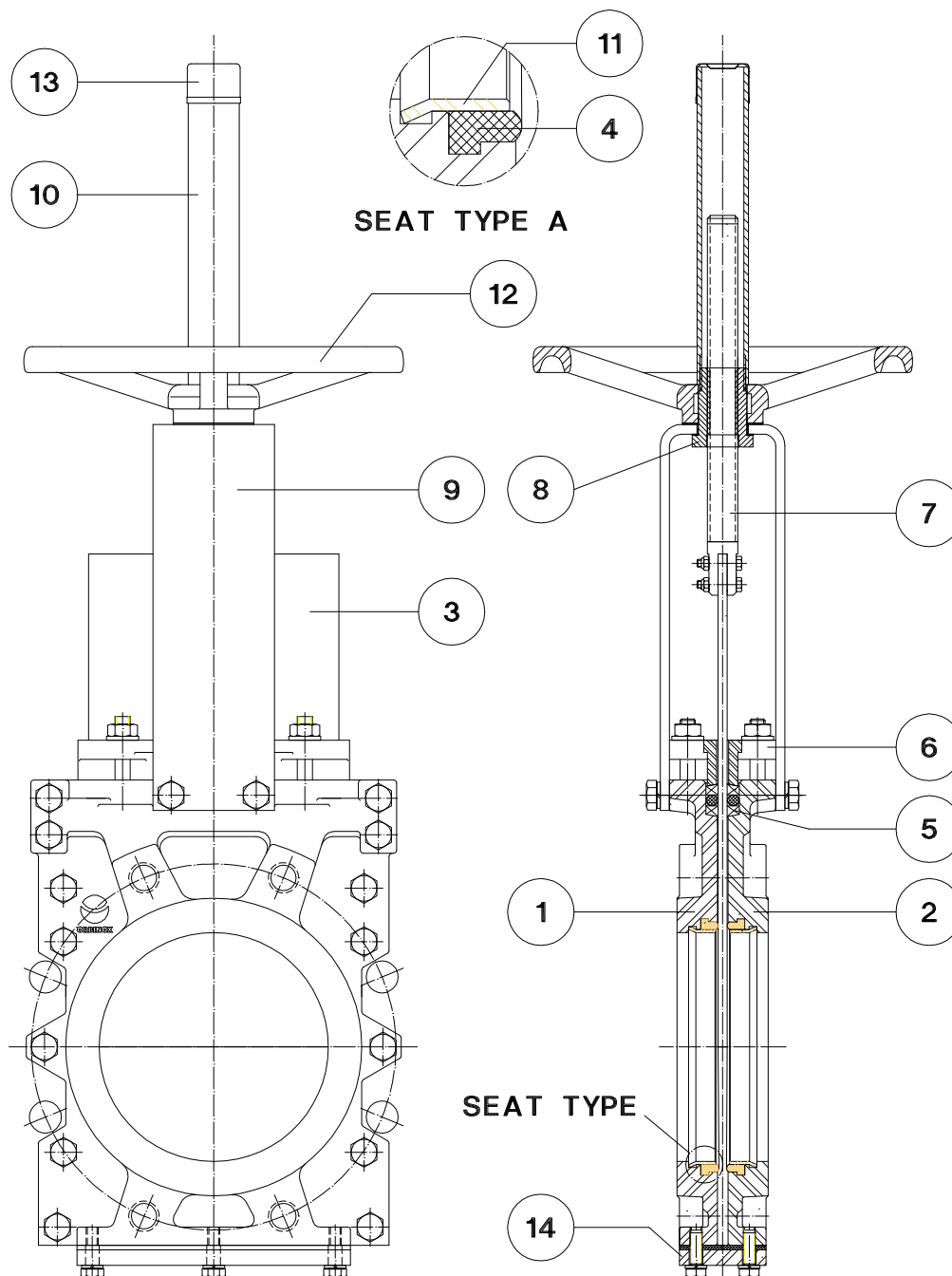

- 1. - BODY
- 2. - COUNTERBODY
- 3. - GATE
- 4. - SEAL
- 5. - PACKING
- 6. - GLAND FOLLOWER
- 7. - STEM

- 8. - STEM NUT
- 9. - YOKE
- 10. - STEM PROTECTOR
- 11. - SEAL RETAINER RING
- 12. - HANDWHEEL
- 13. - CAP
- 14. - COVER